

# SPECIFICATION

---

[Product Name : LPM013M126C]

# CONTENTS

<b>1. BASIC SPECIFICATIONS</b> .....	<b>1</b>
1.1 STRUCTURES .....	1
1.2 BLOCK DIAGRAM .....	2
1.3 DISPLAY ADDRESS MAP AND PIXEL LAYOUT .....	3
1.4 I/O PINS .....	4
<b>2. ABSOLUTE MAXIMUM RATINGS (VSS=0V)</b> .....	<b>5</b>
<b>3. OPERATING CONDITIONS</b> .....	<b>6</b>
3.1 POWER SUPPLY VOLTAGE AND INPUT SIGNALS .....	6
<b>4. ELECTRICAL CHARACTERISTICS</b> .....	<b>6</b>
4.1 POWER CONSUMPTION .....	6
4.2 INPUT SIGNAL CHARACTERISTICS .....	7
4.3 POWER ON/OFF SEQUENCE .....	8
<b>5. MODE</b> .....	<b>9</b>
5.1 MODE TABLE .....	9
5.2 MODE CHART .....	9
<b>6. TIMING CHART AND DETAILS OF MODE</b> .....	<b>10</b>
6.1 SINGLE LINE UPDATE MODE (3BIT-DATA MODE) .....	10
6.2 MULTIPLE LINES UPDATE MODE (3BIT-DATA MODE) .....	11
6.3 SINGLE LINE UPDATE MODE (1BIT-DATA MODE) .....	12
6.4 MULTIPLE LINES UPDATE MODE (1BIT-DATA MODE) .....	13
6.5 SINGLE LINE UPDATE MODE (4BIT-DATA MODE) .....	14
6.6 MULTIPLE LINES UPDATE MODE (4BIT-DATA MODE) .....	15
6.7 NO-UPDATE MODE .....	16
6.8 ALL CLEAR MODE .....	17
6.9 DISPLAY BLINKING COLOR MODE .....	18
6.10 DISPLAY COLOR INVERSION MODE .....	19
<b>7. COM INVERSION</b> .....	<b>20</b>
7.1 COM POLARITY SERIAL INPUT / EXTMODE = "L" .....	20
7.2 EXTCOMIN SIGNAL / EXTMODE="H" .....	20
<b>8. GATE ADDRESS TABLE</b> .....	<b>21</b>
<b>9. OPTICAL SPECIFICATION</b> .....	<b>22</b>
9.1 OPTICAL CHARACTERISTICS .....	22
9.2 DEFINITION AND CONDITION OF OPTICAL CHARACTERISTICS .....	23
<b>10. INSPECTION</b> .....	<b>25</b>
<b>11. RELIABILITY TEST</b> .....	<b>26</b>
11.1 CONDITIONS OF RELIABILITY AND MECHANICAL TEST .....	26
11.2 CRITERIA FOR JUDGEMENT .....	26
<b>12. DESIGNATION OF LOT MARK</b> .....	<b>27</b>
12.1 LOT MARK .....	27
<b>13. PACKING SPECIFICATIONS</b> .....	<b>28</b>
13.1 INNER CARTON .....	28
13.2 MASTER CARTON .....	29
<b>14. LCD MODULE USAGE AND PRECAUTIONS</b> .....	<b>30</b>
14.1 HANDLING .....	30
14.2 DESIGN OF APPLICATION .....	31
14.3 DISPLAY CHARACTERISTICS .....	31

# CONTENTS

14.4 KEEPING THE PRODUCTS .....	31
14.5 DISPOSAL .....	32
14.6 OTHERS .....	32
<b>15. OUTLINE DRAWING .....</b>	<b>33</b>

## 1. BASIC SPECIFICATIONS

This product is the System on the Glass display with SPI(Serial Peripheral Interface) featuring MIP(Memory In Pixel) function which is low power technology.

This display is the reflective LCD, therefore the specification is defined in reflective mode only unless otherwise specified in this specification sheet.

### 1.1 STRUCTURES

No.	FACTOR	SPECIFICATIONS	UNIT
1	LCD structure	LTPS (Memory in Pixel type)	-
2	Outward *1 (W x H x D)	26.62 x 29.72 x 1.45 *1)	mm
3	Weight	1.6(typ.)	g
4	Screen size	23.02(H) x 23.02(V) (1.282 inch)	mm
5	Resolution	176 x RGB x 176	dot
6	Dot pitch (Horizontal x Vertical)	0.0436 x 0.1308	mm
7	Dot layout	RGB stripe	-
8	Liquid crystal mode	ECB normally black (Reflective type)	-
9	Number of colors	8 colors	-
10	Interface	SPI (Serial Peripheral Interface)	-
11	Polarizer	Hard Coat type (*Pencil Hardness : 2H)	-
12	Light source type	Backlight with white LED (2 chips *2)	-

\*1 ) Excluding FPC and part of protruding. See attached drawing for details.

\*2 ) Each LED is connected in parallel in Backlight-FPC.

**1.2 BLOCK DIAGRAM**

The block diagram of a panel is shown below.

**1.2.1 PIN LAYOUT AND INTERNAL CIRCUIT**

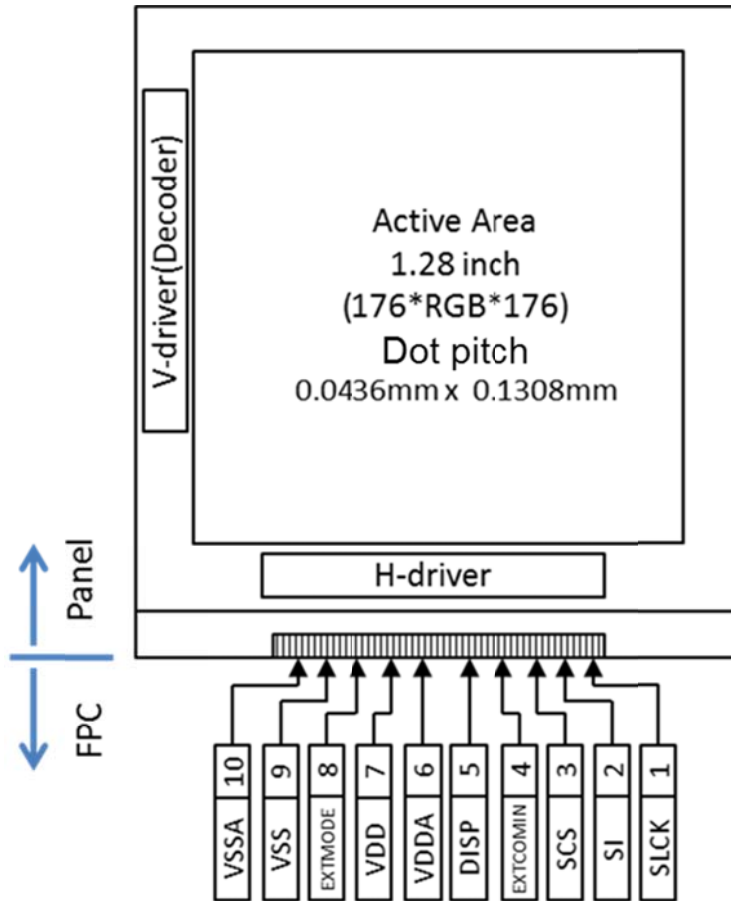

Viewing in front of an LCD panel

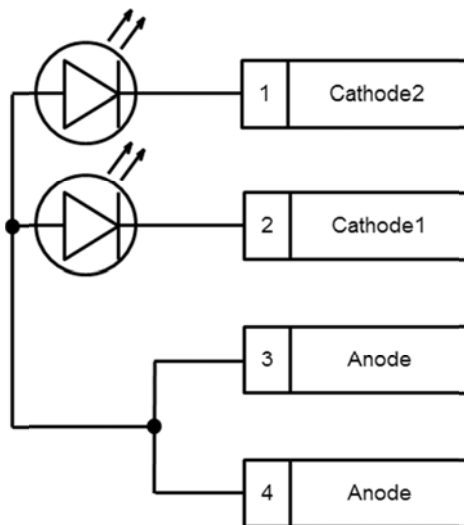

Circuit of Backlight with white LED

1.3 DISPLAY ADDRESS MAP AND PIXEL LAYOUT

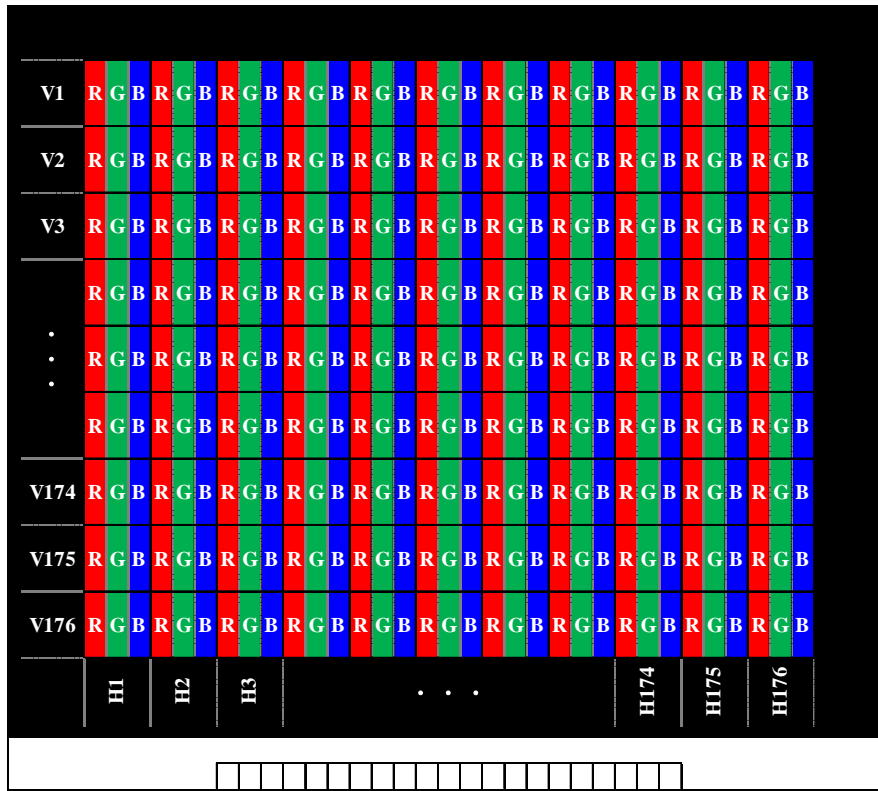

Pixels indicated "RGB" are displayed

Number of active pixels: 176 x RGB x 176 dot

(Viewing in front of an LCD panel)

H1...176 x RGB : Horizontal line

V1...176 : Vertical line

## 1.4 I/O PINS

### 1.4.1 LCD FPC

PIN	SYMBOL	FUNCTION	I/O	REMARKS
1	SCLK	Serial Clock Signal	I	
2	SI	Serial Data Input Signal	I	
3	SCS	Chip Select Signal	I	
4	EXTCOMIN	COM Inversion Polarity Input	I	
5	DISP	Display ON/OFF Switching Signal	I	(*1-1)
6	VDDA	Power Supply for Analog	P	
7	VDD	Power Supply for Logic	P	
8	EXTMODE	COM Inversion Mode Select Terminal	I	(*1-2)
9	VSS	Logic Ground	P	
10	VSSA	Analog Ground	P	

P: Power supply, I: Input

Note)

(\*1-1) ON/OFF switching signal is only for display. Data memory is kept at the time of ON/OFF.

"H" : Data memory is displayed.

"L" : Black color is displayed with data memory kept.

(\*1-2)

"H" : Enable EXTCOMIN signal, connect to VDD.

"L" : Enable serial input flag, connect to VSS.

Recommended circuit

EXTMODE=L : COM Signal Serial Input

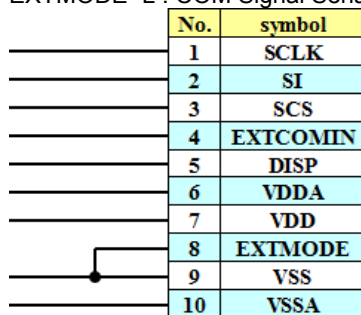

EXTMODE=H : COM Signal External Input

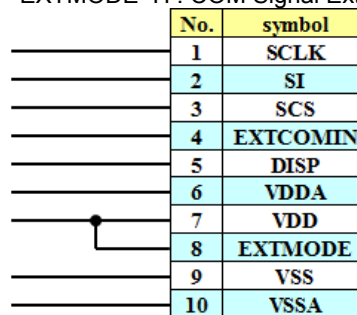

External circuit example

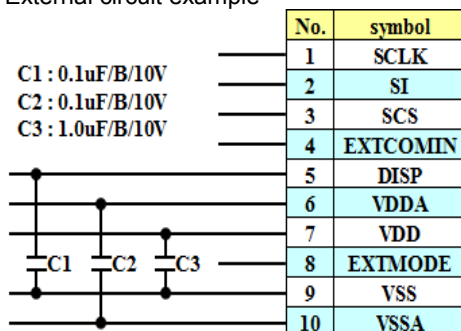

### 1.4.2 BACKLIGHT FPC

PIN	SYMBOL	FUNCTION	I/O	REMARKS
1	Cathode2	Power Supply for LED backlight	P	(*1-3)
2	Cathode1	Power Supply for LED backlight	P	(*1-3)
3	Anode	Power Supply for LED backlight	P	(*1-4)
4	Anode	Power Supply for LED backlight	P	(*1-4)

P: Power supply

Note)

(\*1-3) Each LED is connected in parallel.

(\*1-4) 3Pin and 4Pin (Anode pins) are connected in Backlight-FPC.

## 2. ABSOLUTE MAXIMUM RATINGS (VSS=0V)

PARAMETER	SYMBOL	RATINGS	UNIT	REMARKS
Power supply voltage Analog	VDDA	3.6	V	
Power supply voltage Logic	VDD	3.6	V	
Input signal voltage High	VIH	3.6	V	

PARAMETER	SYMBOL	RATINGS	UNIT	REMARKS
Operating temperature range (LCD panel surface)	Topr	-20 ~ +70	°C	(*2-1)
Storage temperature range	Tstg	-30 ~ +80	°C	(*2-1)

PARAMETER	SYMBOL	RATINGS	UNIT	REMARKS
LED forward current	Iled	30	mA	(*2-2)

Note)

(\*2-1): Maximum humidity is defined as follows:

Ta ≤ 40°C : 85%RH Max.

Ta &gt; 40°C : Absolute humidity needs to be equal or less than the numeric value at the condition of Ta=40°C, 85%RH.

Don't condense dew.

(\*2-2): Ambient Temperature vs Allowable Forward Current is due to the following graph.



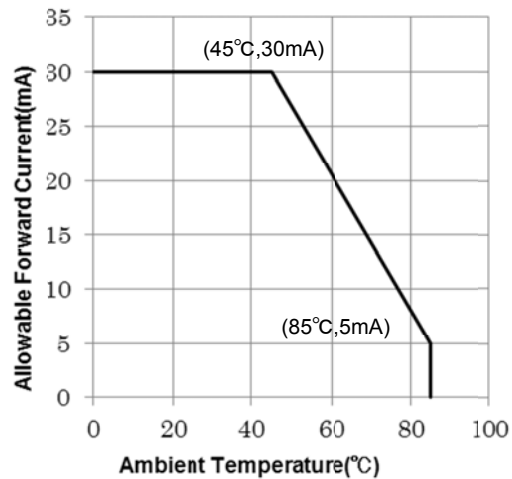

### 3. OPERATING CONDITIONS

#### 3.1 POWER SUPPLY VOLTAGE AND INPUT SIGNALS

PARAMETER	SYMBOL	Min.	Typ.	Max.	UNIT	REMARKS
Power supply voltage Analog	VDDA	2.7	3.0	VDD	V	
	VSSA	-	0	-	V	
Power supply voltage Logic	VDD	2.7	3.0	3.3	V	(*3-1)
	VSS	-	0	-	V	(*3-2)
Input signal voltage High	VIH	VDD-0.1	3.0	VDD	V	(*3-3)
Input signal voltage Low	VIL	VSS	VSS	VSS+0.1	V	(*3-3)
Backlight forward voltage	VF	(2.62)	(2.67)	(2.72)	V	(*3-4)

Note)

(\*3-1) Apply to EXTMODE="H"

(\*3-2) Apply to EXTMODE="L"

(\*3-3) Apply to SCLK, SI, SCS, DISP, EXTCOMIN

(\*3-4) IF : Equivalent to 2.5(mA/each LED)

### 4. ELECTRICAL CHARACTERISTICS

#### 4.1 POWER CONSUMPTION

\* Ta=25°C, Driving Condition : VDD=3.0V, VDDA=3.0V, VIH=3.0V, VIL=0V, Frame frequency=1Hz, COM frequency=0.5Hz

Mode	Display	Min.	Typ.	Max.	UNIT	REMARKS
No update mode	White raster	-	2	105	uW	(*4-0)
Data update mode	White raster	-	10	116	uW	3bit all lines data (*4-0)

Note)

(\*4-0) Excluding LED backlight power consumption.

## 4.2 INPUT SIGNAL CHARACTERISTICS

\* Ta=25°C, Driving Condition : VDD=3.0V, VDDA=3.0V, VIH=3.0V, VIL=0V

PARAMETER	SYMBOL	Min.	Typ.	Max.	UNIT	REMARKS
Clock frequency	fSCLK	-	1.00	2.00	MHz	(*4-1)
COM frequency	fCOM	0.5	-	70	Hz	(*4-2)
SCS rising time	trSCS	-	-	50	ns	
SCS falling time	tfSCS	-	-	50	ns	
SCS Low width	twSCSL	6.0	-	-	us	
SCS settling time	tsSCS	6.0	-	-	us	
SCS holding time	thSCS	2.0	-	-	us	(*4-3)
SI rising time	trSI	-	-	50	ns	
SI falling time	tfSI	-	-	50	ns	
SI settling time	tsSI	200	450	-	ns	
SI holding time	thSI	250	500	-	ns	
SCLK rising time	trSCLK	-	-	50	ns	
SCLK falling time	tfSCLK	-	-	50	ns	
SCLK High width	twSCLKH	250	500	-	ns	(*4-4)
SCLK Low width	twSCLKL	250	500	-	ns	(*4-4)
EXTCOMIN frequency	fEXTCOMIN	1	-	140	Hz	
EXTCOMIN rising time	trEXTCOMIN	-	-	50	ns	
EXTCOMIN falling time	tfEXTCOMIN	-	-	50	ns	
EXTCOMIN High width	twEXTCOMIN	2.0	-	-	us	
DISP rising time	trDISP	-	-	50	ns	
DISP falling time	tfDISP	-	-	50	ns	

Note)

(\*4-1) Please note that Max. fSCLK may be lowered when VDD and VDDA fall than 3.0V at a low temperature.

(\*4-2) COM frequency should be around 60Hz (EXTCOMIN frequency : around 120Hz) for transmissive mode.

(\*4-3) In case of data update mode in transmissive mode, thSCS should be 50us or less.

(\*4-4) twSCLKH and twSCLKL should be approximately the same length, if possible.

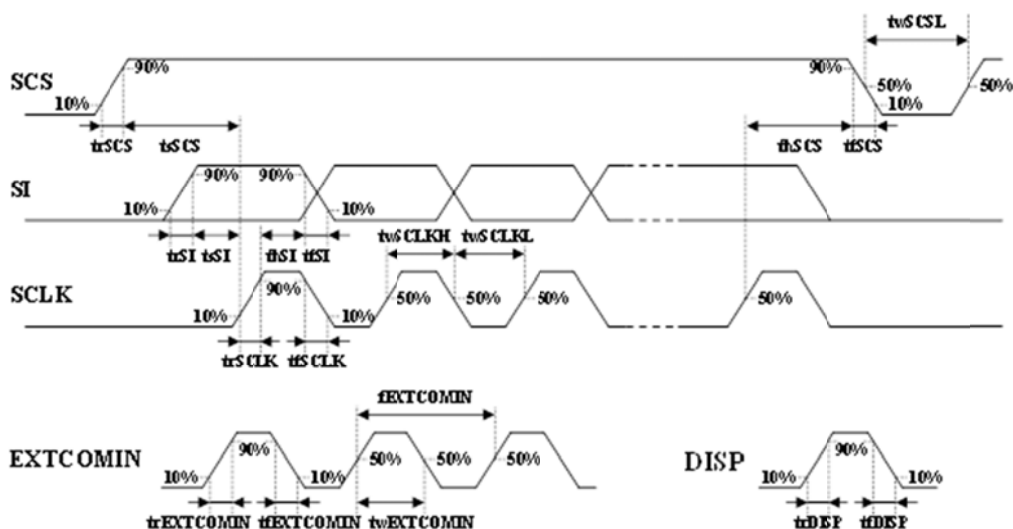

### 4.3 POWER ON/OFF SEQUENCE

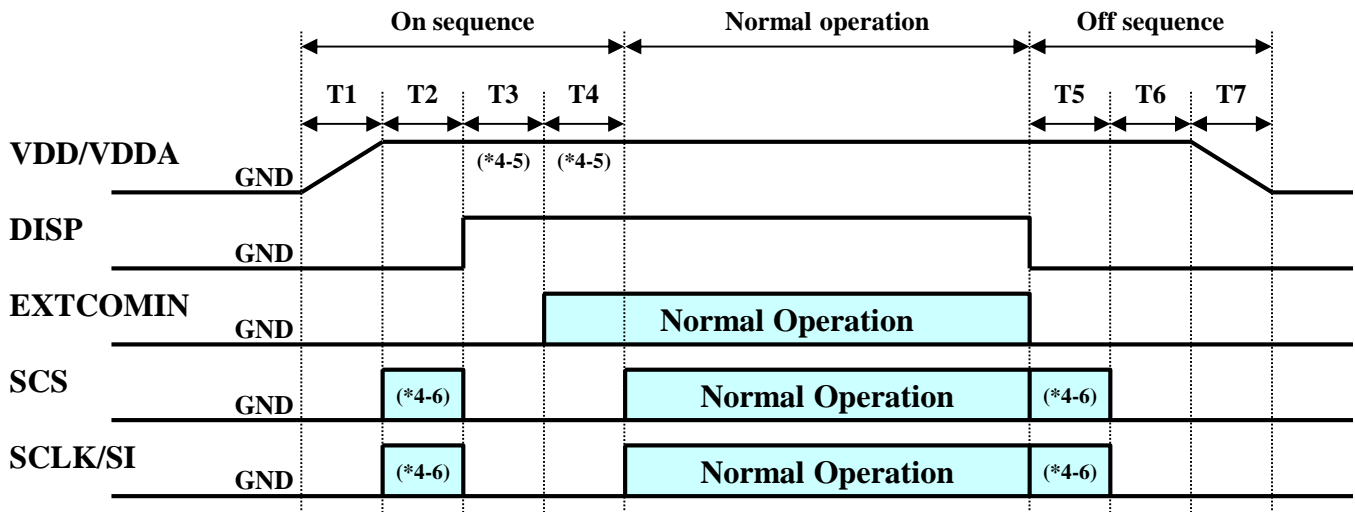

#### [On sequence]

T1 : Power supply rising time. (Depends on external power supply)

T2 : Pixel memory initialization. 1ms or more initialize with M2 (all clear flag).

T3 : Release time for internal latch circuits. 30us or more

T4 : COM polarity initialization time. 30us or more

#### [Normal operation]

Duration of normal operation

#### [Off sequence]

T5 : Pixel memory initialization. Same as T2.

T6 : COM and latch circuits initialization. 30us or more

T7 : Power supply falling time. (Depends on external power supply)

#### Note)

Refer to the timing chart and electrical characteristics for details.

(\*4-5) It is allowed to replace T3 and T4 mutually.

In case of starting EXTCOMIN before rising DISP, EXTCOMIN is ignored during DISP="L".

Also, it is allowed to start simultaneously DISP and EXTCOMIN.

In that case, need 100us or more (200us or less) before normal operation.

(\*4-6) Pixel memory initialization.

Use M2 (all clear flag : refer to 6.8),

or write black data to all pixel memories (refer to the data update mode).

#### [Remark]

VDD and VDDA should rise simultaneously or VDD should rise first.

VDD and VDDA should fall simultaneously or VDDA should fall first.

## 5. MODE

### 5.1 MODE TABLE

#### Mode select

Unassigned bit and AG9-8 : No care, it can be H or L (L is Recommended)

M0	M1	M2	M3	M4	M5	AG9	AG8	AG7	AG6	AG5	AG4	AG3	AG2	AG1	AG0	Mode
L	L/H	L	L	-	-	-	-	-	-	-	-	-	-	-	-	No-Update
L	L/H	L	H	L/H	L/H	-	-	-	-	-	-	-	-	-	-	Blinking
L	L/H	H	L/H	L/H	L/H	-	-	-	-	-	-	-	-	-	-	All Clear
H	L/H	L	L/H	L/H	-	AG9	AG8	AG7	AG6	AG5	AG4	AG3	AG2	AG1	AG0	Data-Update
H	L/H	H	L/H	L/H	L/H	-	-	-	-	-	-	-	-	-	-	No-Update

Mode (6bit)
Gate Address (10bit)

#### Function table

M0=L or M0=H/M2=H

Mode	M3	M4	M5
Blinking OFF	L	-	-
Blink Black	H	L	L
Blink White	H	H	L
Blink Inversion	H	-	H

M0=H/M2=L

Mode	M3	M4	M5
3bit data input	L	L	-
1bit data input	L	H	-
4bit data input	H	-	-

Unassigned bit : No care, it can be H or L (L is Recommended)

### 5.2 MODE CHART

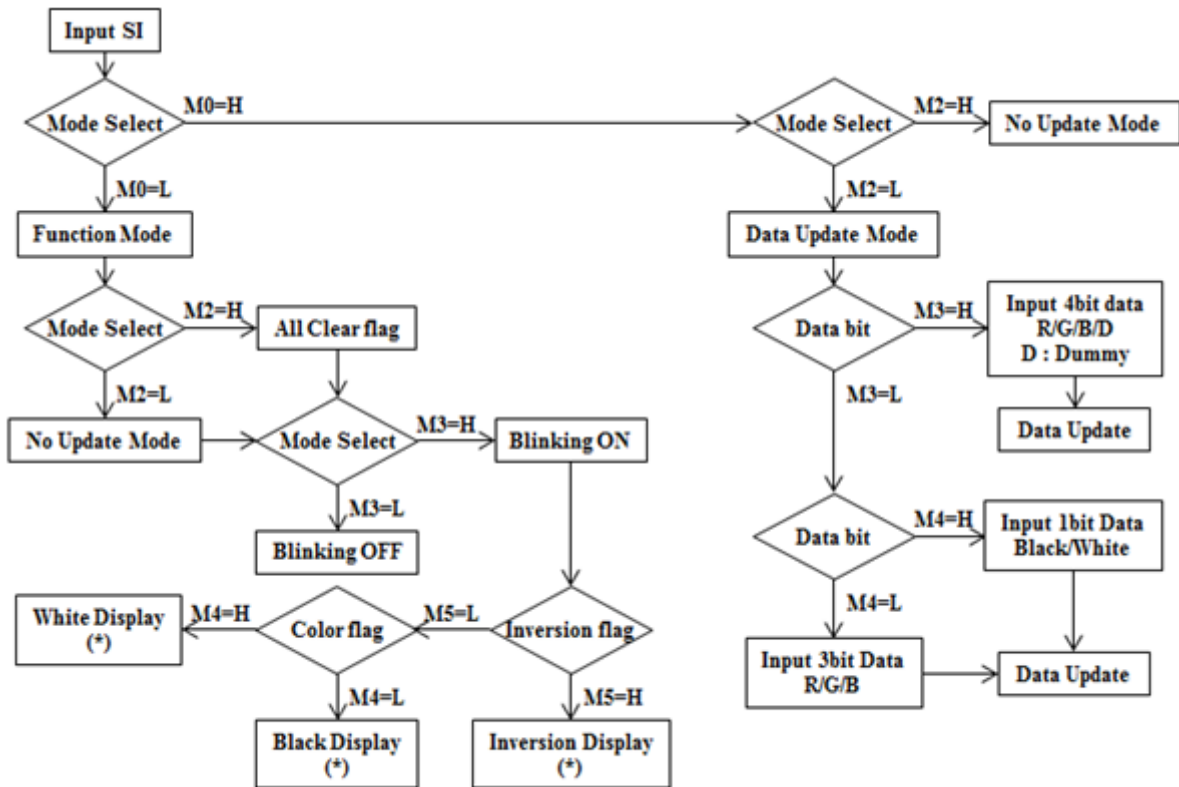

(\*) Pixel memories are kept.

## 6. TIMING CHART AND DETAILS OF MODE

### 6.1 SINGLE LINE UPDATE MODE (3BIT-DATA MODE)

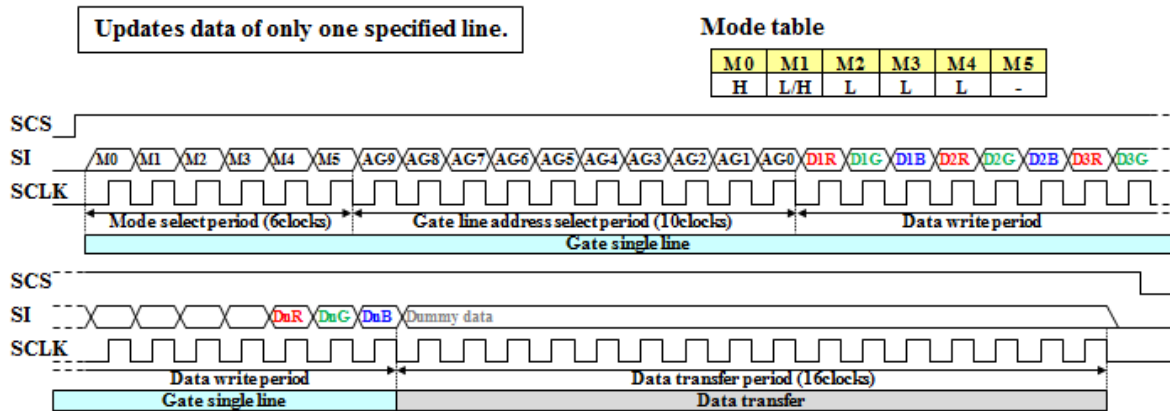

M0 : Mode flag. Set "H", data update mode.

M1 : COM inversion flag. In case of EXTMODE="L", validate.

In case of "H", outputs COM="H".

In case of "L", outputs COM="L".

In case of EXTMODE="H", invalidate, it can be "H" or "L".

M2 : All clear flag. Set "L", data update mode.

M3-M4 : Data-bit control flag. In case of M3="L" and M4="L", 3bit-data mode.

M5 : Invalid data, it can be "H" or "L".

AG9-AG0 : Gate line address (10bit), refer to the GATE ADDRESS TABLE.

Data : Pixel memory data. In case of "L", pixel is black.

In case of 3bit-data mode,

input serially the pixel data in the order of Red-Green-Blue (3bit).

n : Number of horizontal line, refer to the DISPLAY ADDRESS MAP AND PIXEL LAYOUT.

Dummy data : It can be "H" or "L".

Need transfer period which is 16clocks after the last data.

M0, M2 flags are cleared by SCS="L", and M3-M4 flags are cleared by DISP="L".

## 6.2 MULTIPLE LINES UPDATE MODE (3BIT-DATA MODE)

Updates arbitrary multiple lines data.

Mode table

M0	M1	M2	M3	M4	M5
H	L/H	L	L	L	-

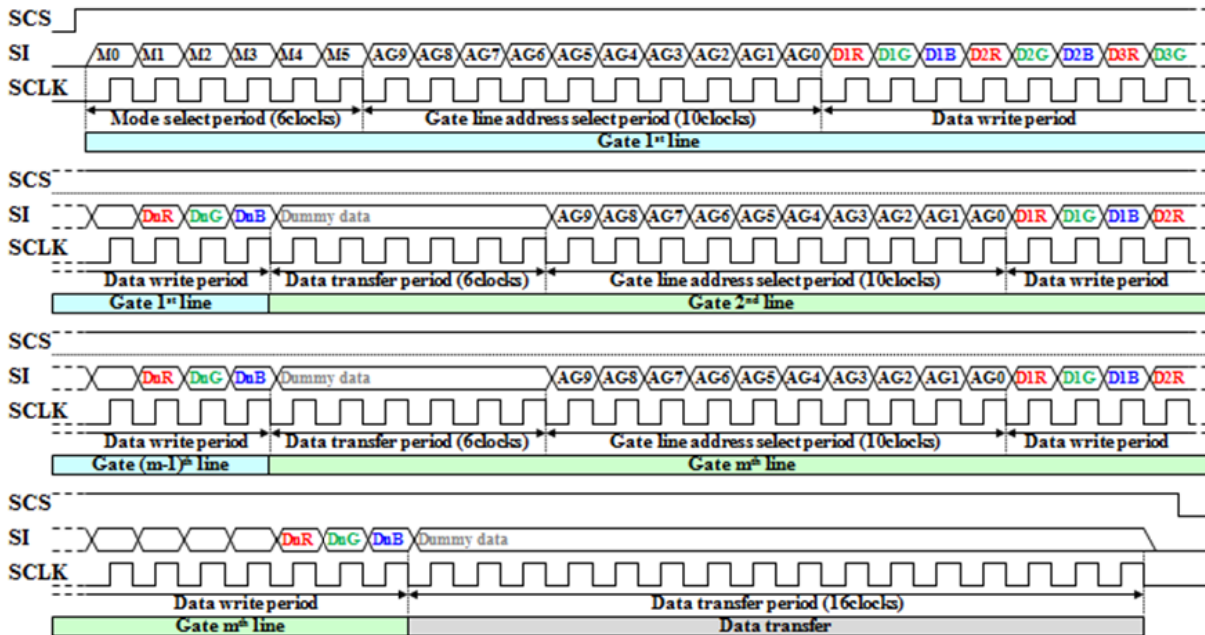

M0 : Mode flag. Set "H", data update mode.

M1 : COM inversion flag. In case of EXTMODE="L", validate.

In case of "H", outputs COM="H".

In case of "L", outputs COM="L".

In case of EXTMODE="H", invalidate, it can be "H" or "L".

M2 : All clear flag. Set "L", data update mode.

M3-M4 : Data-bit control flag. In case of M3="L" and M4="L", 3bit-data mode.

M5 : Invalid data, it can be "H" or "L".

AG9-AG0 : Gate line address (10bit), refer to the GATE ADDRESS TABLE.

Data : Pixel memory data. In case of "L", pixel is black.

In case of 3bit-data mode,

input serially the pixel data in the order of Red-Green-Blue (3bit).

n : Number of horizontal line, refer to the DISPLAY ADDRESS MAP AND PIXEL LAYOUT.

Dummy data : It can be "H" or "L".

Input data continuously.

m : Number of vertical line, refer to the DISPLAY ADDRESS MAP AND PIXEL LAYOUT.

Need transfer period which is 6clocks between the gate line and the next gate line.

Need transfer period which is 16clocks after the last data.

M0, M2 flags are cleared by SCS="L", and M3-M4 flags are cleared by DISP="L".

### 6.3 SINGLE LINE UPDATE MODE (1BIT-DATA MODE)

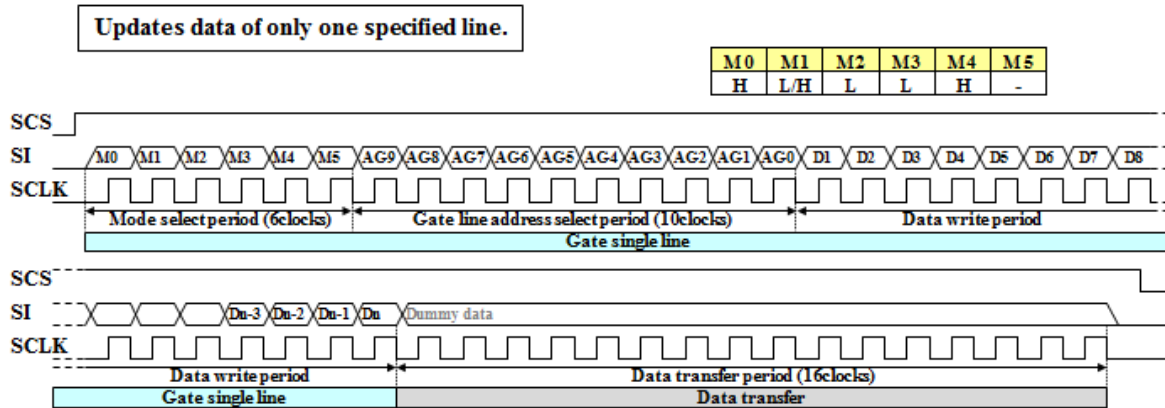

M0 : Mode flag. Set "H", data update mode.

M1 : COM inversion flag. In case of EXTMODE="L", validate.

In case of "H", outputs COM="H".

In case of "L", outputs COM="L".

In case of EXTMODE="H", invalidate, it can be "H" or "L".

M2 : All clear flag. Set "L", data update mode.

M3-M4 : Data-bit control flag. In case of M3="L" and M4="H", 1bit-data mode.

M5 : Invalid data, it can be "H" or "L".

AG9-AG0 : Gate line address (10bit), refer to the GATE ADDRESS TABLE.

Data : Pixel memory data. In case of "L", pixel is black.

In case of 1bit-data mode, input the pixel data "H" or "L" (1bit).

Pixel memories of red, green and blue are written the same data.

n : Number of horizontal line, refer to the DISPLAY ADDRESS MAP AND PIXEL LAYOUT.

Dummy data : It can be "H" or "L".

Need transfer period which is 16clocks after the last data.

M0, M2 flags are cleared by SCS="L", and M3-M4 flags are cleared by DISP="L".

#### 6.4 MULTIPLE LINES UPDATE MODE (1BIT-DATA MODE)

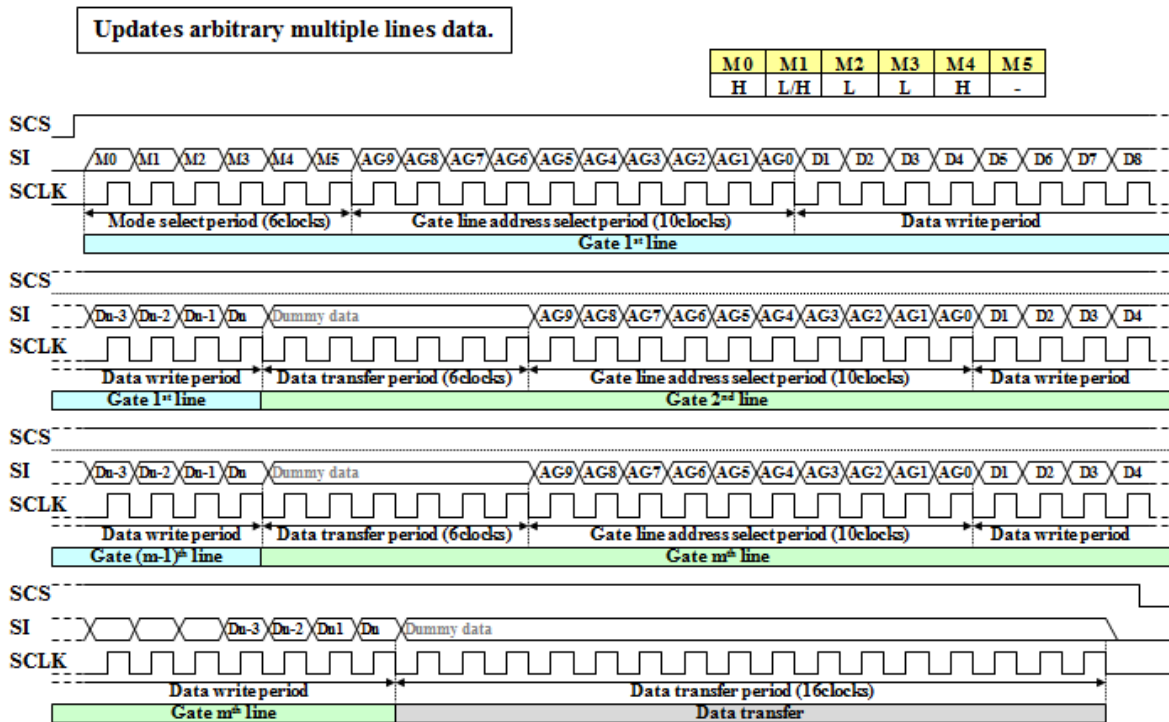

M0 : Mode flag. Set "H", data update mode.

M1 : COM inversion flag. In case of EXTMODE="L", validate.

In case of "H", outputs COM="H".

In case of "L", outputs COM="L".

In case of EXTMODE="H", invalidate, it can be "H" or "L".

M2 : All clear flag. Set "L", data update mode.

M3-M4 : Data-bit control flag. In case of M3="L" and M4="H", 1bit-data mode.

M5 : Invalid data, it can be "H" or "L".

AG9-AG0 : Gate line address (10bit), refer to the GATE ADDRESS TABLE.

Data : Pixel memory data. In case of "L", pixel is black.

In case of 1bit-data mode, input the pixel data "H" or "L" (1bit).

Pixel memories of red, green and blue are written the same data.

n : Number of horizontal line, refer to the DISPLAY ADDRESS MAP AND PIXEL LAYOUT.

Dummy data : It can be "H" or "L".

Input data continuously.

m : Number of vertical line, refer to the DISPLAY ADDRESS MAP AND PIXEL LAYOUT.

Need transfer period which is 6clocks between the gate line and the next gate line.

Need transfer period which is 16clocks after the last data.

M0, M2 flags are cleared by SCS="L", and M3-M4 flags are cleared by DISP="L".



## 6.5 SINGLE LINE UPDATE MODE (4BIT-DATA MODE)

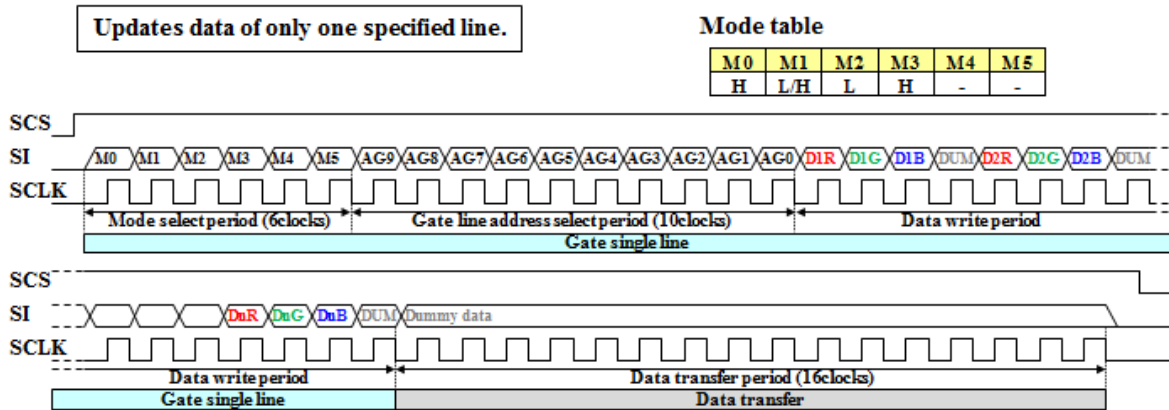

M0 : Mode flag. Set "H", data update mode.

M1 : COM inversion flag. In case of EXTMODE="L", validate.

In case of "H", outputs COM="H".

In case of "L", outputs COM="L".

In case of EXTMODE="H", invalidate, it can be "H" or "L".

M2 : All clear flag. Set "L", data update mode.

M3 : Data-bit control flag. In case of M3="H", 4bit-data mode.

M4-M5 : Invalid data, it can be "H" or "L".

AG9-AG0 : Gate line address (10bit), refer to the GATE ADDRESS TABLE.

Data : Pixel memory data. In case of "L", pixel is black.

In case of 4bit-data mode,

input serially the pixel data in the order of Red-Green-Blue-Dummy (4bit).

Dummy data (DUM) can be "H" or "L".

n : Number of horizontal line, refer to the DISPLAY ADDRESS MAP AND PIXEL LAYOUT.

Dummy data : It can be "H" or "L".

Need transfer period which is 16clocks after the last data.

M0, M2 flags are cleared by SCS="L", and M3 flag is cleared by DISP="L".

## 6.6 MULTIPLE LINES UPDATE MODE (4BIT-DATA MODE)

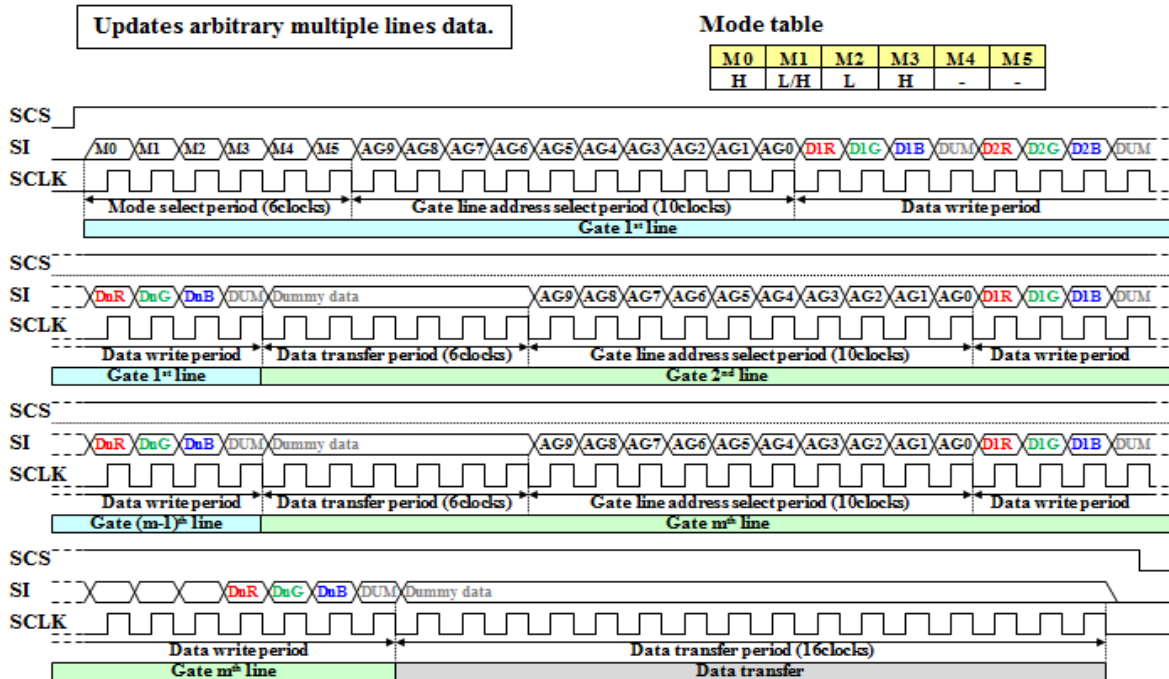

M0 : Mode flag. Set "H", data update mode.

M1 : COM inversion flag. In case of EXTMODE="L", validate.

In case of "H", outputs COM="H".

In case of "L", outputs COM="L".

In case of EXTMODE="H", invalidate, it can be "H" or "L".

M2 : All clear flag. Set "L", data update mode.

M3 : Data-bit control flag. In case of M3="H", 4bit-data mode.

M4-M5 : Invalid data, it can be "H" or "L".

AG9-AG0 : Gate line address (10bit), refer to the GATE ADDRESS TABLE.

Data : Pixel memory data. In case of "L", pixel is black.

In case of 4bit-data mode,

input serially the pixel data in the order of Red-Green-Blue-Dummy (4bit).

Dummy data (DUM) can be "H" or "L".

n : Number of horizontal line, refer to the DISPLAY ADDRESS MAP AND PIXEL LAYOUT.

Dummy data : It can be "H" or "L".

Input data continuously.

m : Number of vertical line, refer to the DISPLAY ADDRESS MAP AND PIXEL LAYOUT.

Need transfer period which is 6clocks between the gate line and the next gate line.

Need transfer period which is 16clocks after the last data.

M0, M2 flags are cleared by SCS="L", and M3 flag is cleared by DISP="L".

## 6.7 NO-UPDATE MODE

**Keeps memory internal data (current display).**

### Mode table

M0	M1	M2	M3	M4	M5
L	L/H	L	L	-	-

M0	M1	M2	M3	M4	M5
H	L/H	H	L	-	-

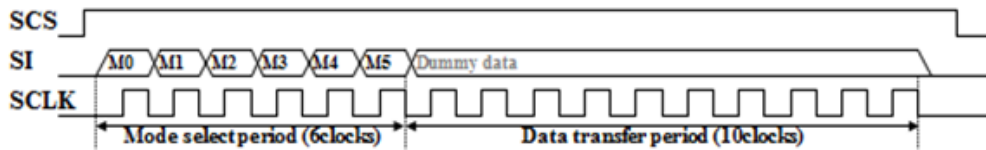

M0 : Mode flag.

M1 : COM inversion flag. In case of EXTMODE="L", validate.

In case of "H", outputs COM="H".

In case of "L", outputs COM="L".

In case of EXTMODE="H", invalidate, it can be "H" or "L".

M2 : All clear flag.

Set "L" or "H" to both M0 and M2, no-update mode.

M3 : Blinking flag. In case of "L", no-update mode and display blinking mode is terminated.

In case of "H", display blinking mode. Refer to 6.9 for details.

M4-M5 : Invalid data, it can be "H" or "L".

Dummy data : It can be "H" or "L".

M0, M2 flags are cleared by SCS="L", and M3 flag is cleared by DISP="L".

## 6.8 ALL CLEAR MODE

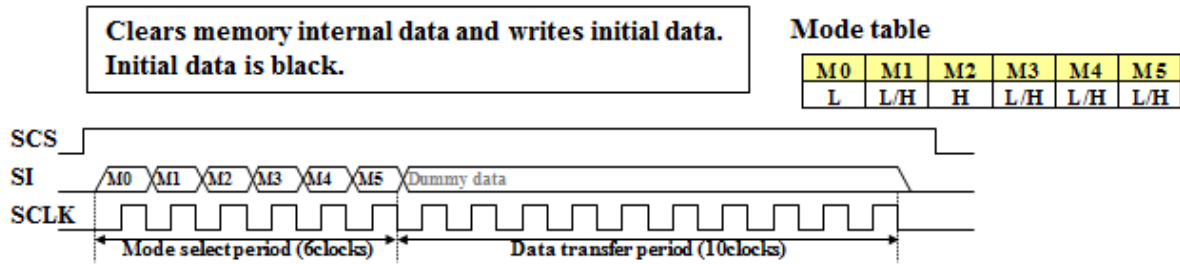

M0 : Mode flag. Set "L", no-update mode.

M1 : COM inversion flag. In case of EXTMODE="L", validate.

In case of "H", outputs COM="H".

In case of "L", outputs COM="L".

In case of EXTMODE="H", invalidate, it can be "H" or "L".

M2 : All clear flag. Set "H", all clear mode.

M3 : Blinking flag. In case of "L", display blinking mode is terminated.

In case of "H", display blinking mode. Refer to 6.9 for details.

M4-M5 : Blinking mode flag. In case of M3="H", validate.

In case of M3="L", invalidate, it can be "H" or "L".

Dummy data : It can be "H" or "L".

M0, M2 flags are cleared by SCS="L", and M3-M4 flags are cleared by DISP="L".

Display gives priority to blinking flag (M3).

6.9 DISPLAY BLINKING COLOR MODE

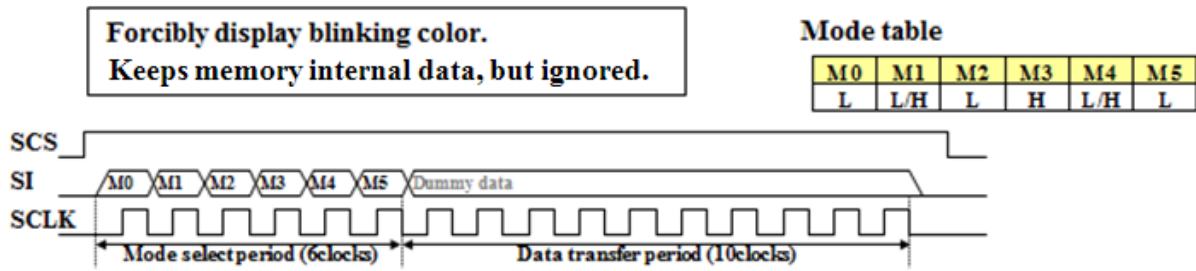

M0 : Mode flag. Set "L", no-update mode.

M1 : COM inversion flag. In case of EXTMODE="L", validate.

In case of "H", outputs COM="H".

In case of "L", outputs COM="L".

In case of EXTMODE="H", invalidate, it can be "H" or "L".

M2 : All clear flag. Set "L", no-update mode.

In case of "H", all clear mode. Refer to 6.8 for details.

M3 : Blinking flag. In case of "H", display blinking mode and forcibly display blinking color.

In case of "L", no-update mode and display blinking mode is terminated.

M4 : Blinking color flag. Apply to display blinking color.

In case of "H", display blinking color is white.

In case of "L", display blinking color is black.

M5 : Blinking inversion flag. Set "L", blinking color mode.

Dummy data : It can be "H" or "L".

M0, M2 flags are cleared by SCS="L", and M3-M5 flags are cleared by DISP="L".

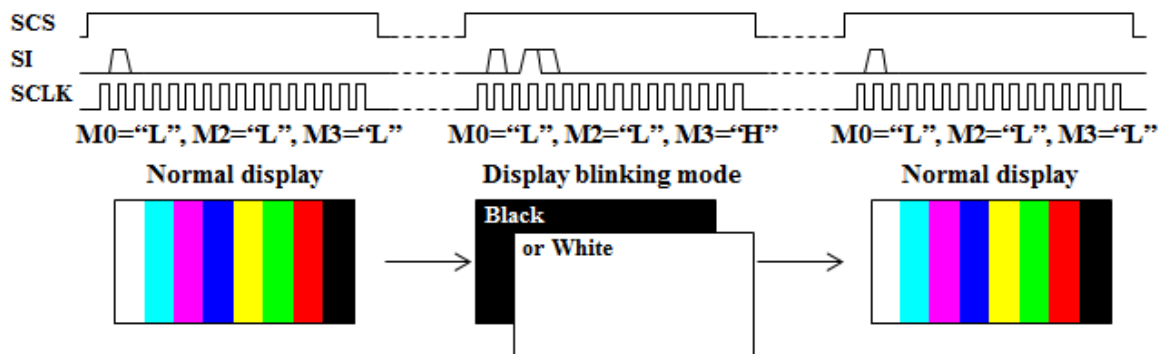

**Blink display to alternate between normal display and display blinking mode.**

## 6.10 DISPLAY COLOR INVERSION MODE

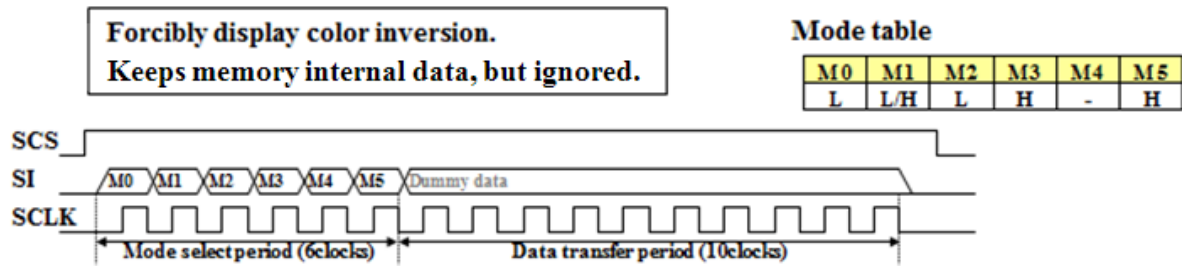

M0 : Mode flag. Set "L", no-update mode.

M1 : COM inversion flag. In case of EXTMODE="L", validate.

In case of "H", outputs COM="H".

In case of "L", outputs COM="L".

In case of EXTMODE="H", invalidate, it can be "H" or "L".

M2 : All clear flag. Set "L", no-update mode.

In case of "H", all clear mode. Refer to 6.8 for details.

M3 : Blinking flag. In case of "H", display blinking mode and forcibly display color inversion.

In case of "L", no-update mode and display blinking mode is terminated.

M4 : Blinking color flag. In case of M5="H", invalidate, it can be "H" or "L".

In case of M5="L", refer to 6.9 for details.

M5 : Color inversion flag. Set "H", display color is inverted.

For example, "Red" is changed to "Cyan".

"Cyan" is complementary color of "Red".

Dummy data : It can be "H" or "L".

M0, M2 flags are cleared by SCS="L", and M3, M5 flags are cleared by DISP="L".

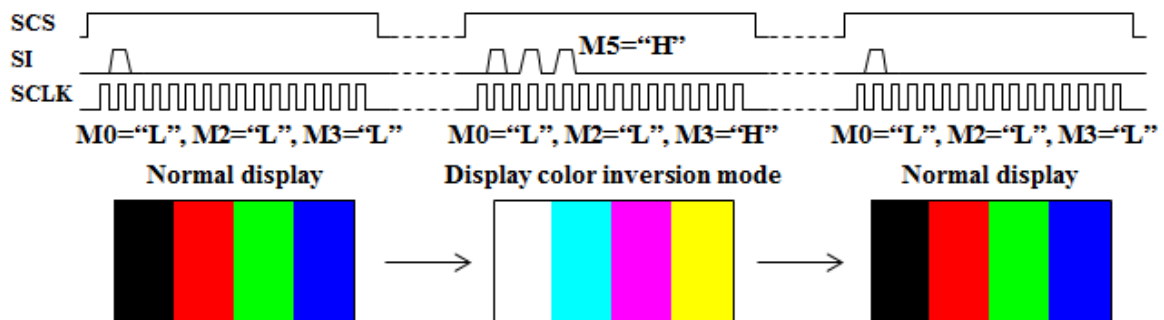

**Blink display to alternate between normal display and display blinking mode.**

## 7. COM INVERSION

### 7.1 COM POLARITY SERIAL INPUT / EXTMODE = "L"

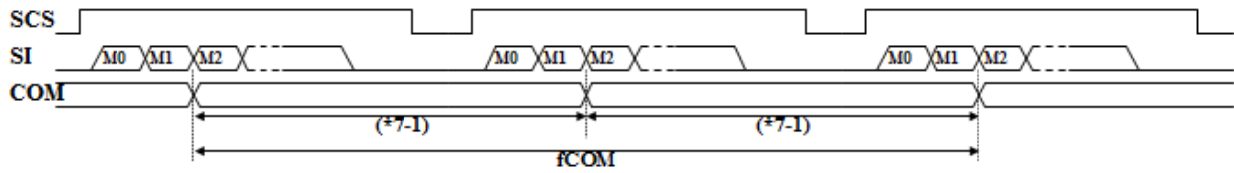

M1 : COM inversion flag. In case of "H", outputs COM="H". In case of "L", outputs COM="L".

COM polarity inversion has been changed by M1 flag statement.

(\*7-1) The periods of positive and negative polarity should be same length as much as possible.

### 7.2 EXTCOMIN SIGNAL / EXTMODE="H"

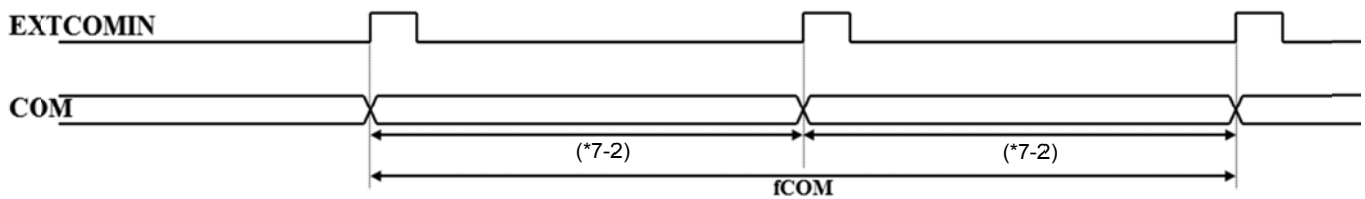

COM polarity inversion has been changed by the rising timing of EXTCOMIN.

COM polarity (positive or negative) is controlled by internal circuit.

(\*7-2) The periods of positive and negative polarity should be same length as much as possible.





## 9. OPTICAL SPECIFICATION

### 9.1 OPTICAL CHARACTERISTICS

#### 9.1.1 REFLECTIVE MODE

\* VDD=3.0V, VDDA=3.0V, VIH=3.0V, VIL=0V

Item	Symbol	Temp. (°C)	Rating			Unit	Definition (Measurement setup)	Remark
			Min.	Typ.	Max.			
Contrast	CR	25	15	30	-	-	1	
Response	<i>tr</i>	25	-	4	8	ms	2	Black → White
	<i>tf</i>		-	6	10			White → Black
Color coordinates	<i>Rx</i>	25	-	0.510	-	-	3	
	<i>Ry</i>		-	0.320	-			
	<i>Gx</i>		-	0.312	-			
	<i>Gy</i>		-	0.453	-			
	<i>Bx</i>		-	0.170	-			
	<i>By</i>		-	0.178	-			
	<i>Wx</i>		-	0.326	-			
	<i>Wy</i>		-	0.343	-			
NTSC ratio	-	25	16	23	-	%	4	
Reflectance	-	25	19	26	-	%	Measurement system-I	
Viewing Angle (CR>2)	θL	25	50	65	-	deg.	5	Horizontal
	θR		50	65	-			Vertical
	θT		50	65	-			
	θB		50	65	-			

#### 9.1.2 TRANSMISSIVE MODE

\*VDD=3.0V, VDDA=3.0V, VIH=3.0V, VIL=0V, Backlight current=5mA (\*9-1)

COM frequency should be around 60Hz (EXTCOMIN frequency : around 120Hz) for transmissive mode.

Item	Symbol	Temp. (°C)	Rating			Unit	Definition (Measurement setup)	Remark
			Min.	Typ.	Max.			
Brightness	<i>B</i>	25	-	10	-	cd/m <sup>2</sup>	Measurement system-II	

Note)

(\*9-1) Backlight current : Equivalent to 2.5(mA/each LED)

## 9.2 DEFINITION AND CONDITION OF OPTICAL CHARACTERISTICS

### 9.2.1 Definitions of optical characteristics

#### Definition 1

This is a ratio between the screen surface reflectance of the white raster and the black raster

$$\text{Contrast ratio (CR)} = \frac{\text{Reflection intensity on all pixels White}}{\text{Reflection intensity on all pixels Black}}$$

#### Definition 2

The response time is defined as the following figure and shall be measured by matching the input signal for "Black" and "White".

- Normally Black mode

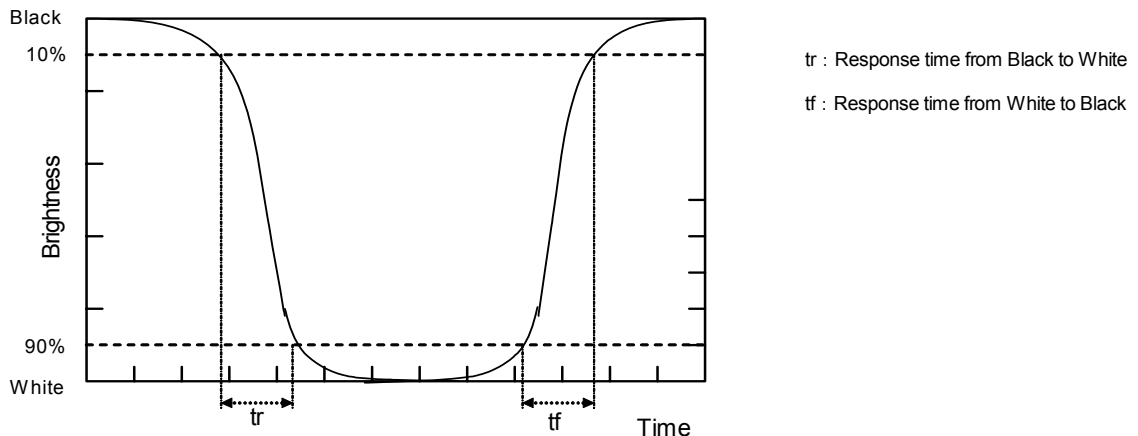

#### Definition 3

This is the x-y coordinate of Red, Green, Blue and White colors specified on the CIE1931 chromaticity diagram. (\* It is not a guaranteed value)

#### Definition 4

This is an area of a triangle shaped by R, G and B coordinates on the CIE1931 chromaticity diagram.

#### Definition 5

This is a maximum angle  $\theta$  from the normal direction that keeps having the contrast more than 2.

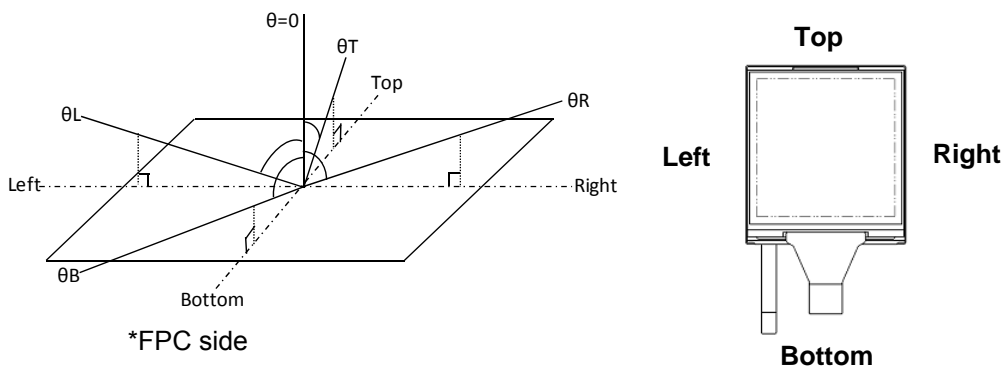

## 9.2.2 Measurement method of optical characteristics

### 9.2.2.1 Basic measurement conditions

a) Driving voltage

VDD=3.0V

VDDA=3.0V

VIH = 3.0V

VIL = 0V

b) Measurement temperature

25°C unless otherwise specified

c) Measurement point

Center of the Active area (one point) unless otherwise specified

### 9.2.2.2 Measurement system- I for reflective mode

d) Measurement equipment

LCD-5200 or equivalent

f) Light source

Parallel light source

- D65 / 2 degree viewing angle
- Light source input direction: opposite side of FPC (30°)
- Light source receive direction: at LCD center (0°)

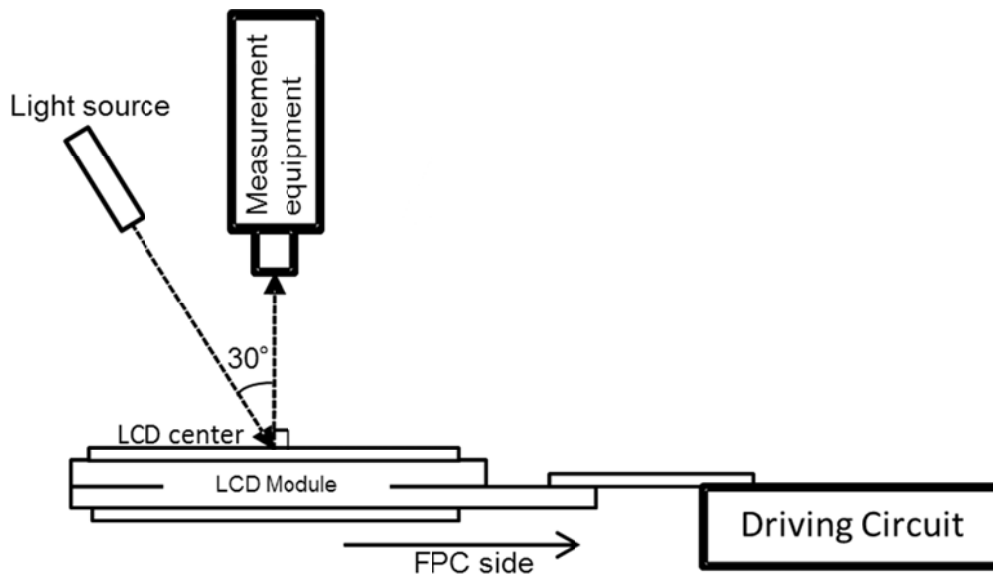

### 9.2.2.3 Measurement system-II for transmissive mode

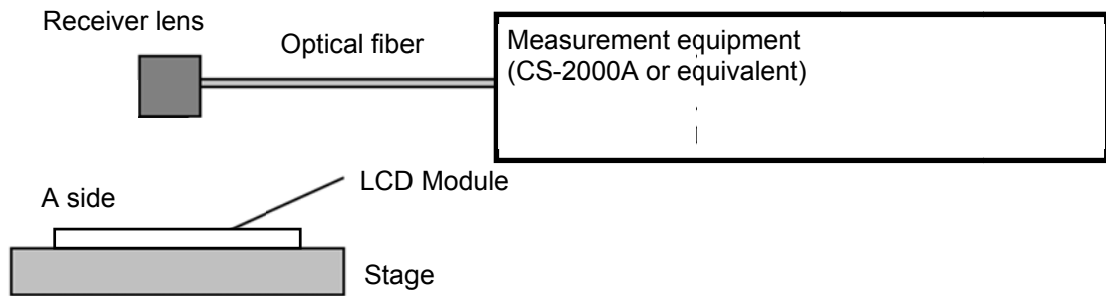

## 10. INSPECTION

Please refer to the shipment inspection standard Ver.03 for LPM013M126C.

**11. RELIABILITY TEST****11.1 CONDITIONS OF RELIABILITY AND MECHANICAL TEST**

No.	TEST ITEM	CONDITION		REMARK
1	High Temperature Storage	Ta=80°C	240h	
2	Low Temperature Storage	Ta=-30°C	240h	
3	High Temperature & High Humidity Storage	Ta=60°C/90%RH (No condensation)	240h	
4	High Temperature & High Humidity Operation	Ta=40°C/90%RH (No condensation)	240h	
5	High Temperature Operation	Ta=70°C	240h	
6	Low Temperature Operation	Ta=-20°C	240h	
7	Thermal shock (non-operating)	Ta=-20°C to 70°C (30min each)	50cycles	
8	ESD	HBM IEC 61340-3-1, ESD STM5.1 V = +/-1.0kV (Contact) R = 1.5kΩ, C = 100pF	1 time each terminal	
9	Shock	100G, 6ms, ±X, ±Y, ±Z	3 times Each direction	
10	Packing Vibration	Random Vibration	101min Direction:Z	
11	Packing Drop	Height 60cm, 1 corner 3 edges, 6 surfaces	1 time Each direction	

Note)

If a nonconformance is found, both parties will have a discussion to solve it.

**11.2 CRITERIA FOR JUDGEMENT**

After the above tests, return samples to the normal temperature and moisture environment in the thermostat chamber room over 30 minutes not to condense. Inspect samples kept for more than 1 hour after pulling them out of the thermostat chamber room.

(1) There shall be no abnormality in the functions (Ex. No display, abnormal display, line defects).

(2) There shall be no serious degradation (Ex. Brightness uniformity, reversible changes, optical changes due to backlight or polarizer are ignored).

**12. DESIGNATION OF LOT MARK**

**12.1 LOT MARK**

Lot mark is printed on the rear of the LCD module.

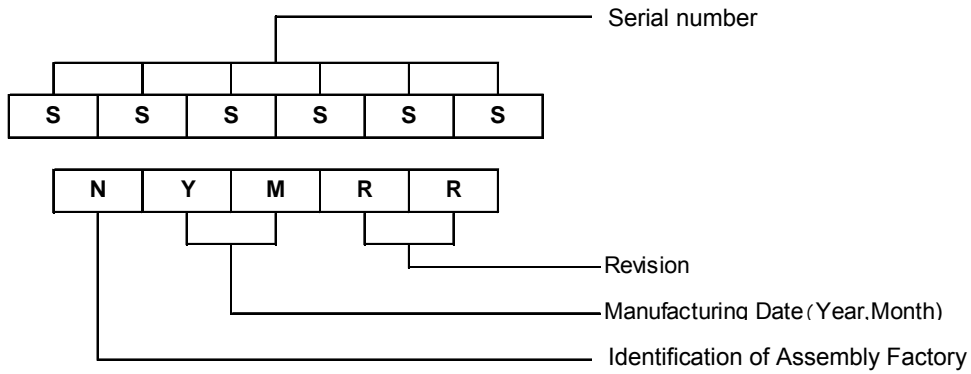
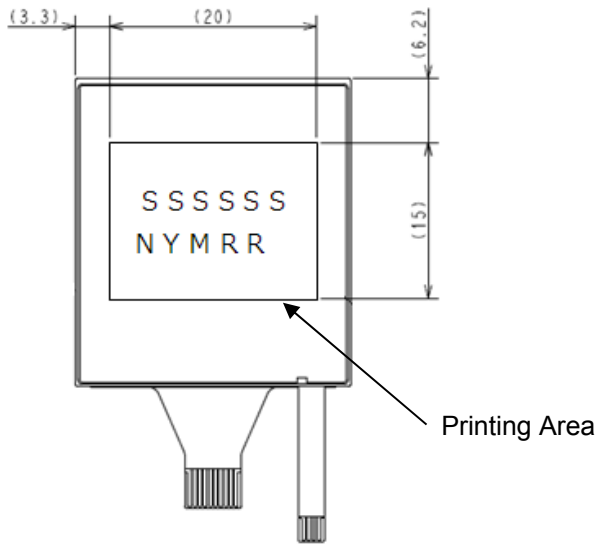

Year	Figure in lot mark
2016	6
2017	7
2018	8
2019	9
2020	0

Month	Figure in lot mark	Month	Figure in lot mark
Jan.	A	Jul.	G
Feb.	B	Aug.	H
Mar.	C	Sep.	I
Apr.	D	Oct.	J
May	E	Nov.	K
Jun.	F	Dec.	L

### 13. PACKING SPECIFICATIONS

#### 13.1 INNER CARTON

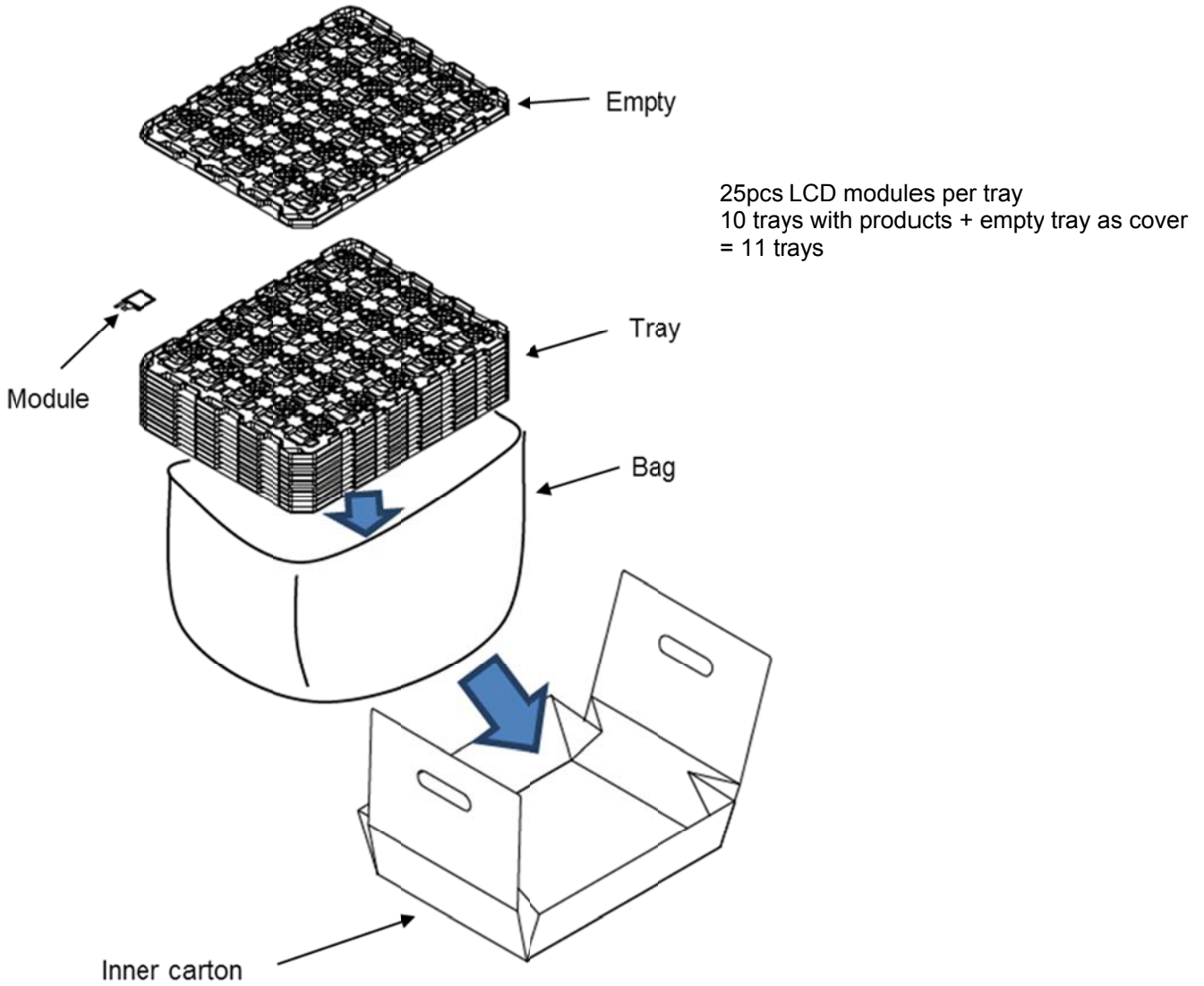

(Note)

Trays orientation should be stacked by turning 180 degrees alternately.

If you do not stack trays alternately, panel gets damaged.

**13.2 MASTER CARTON**

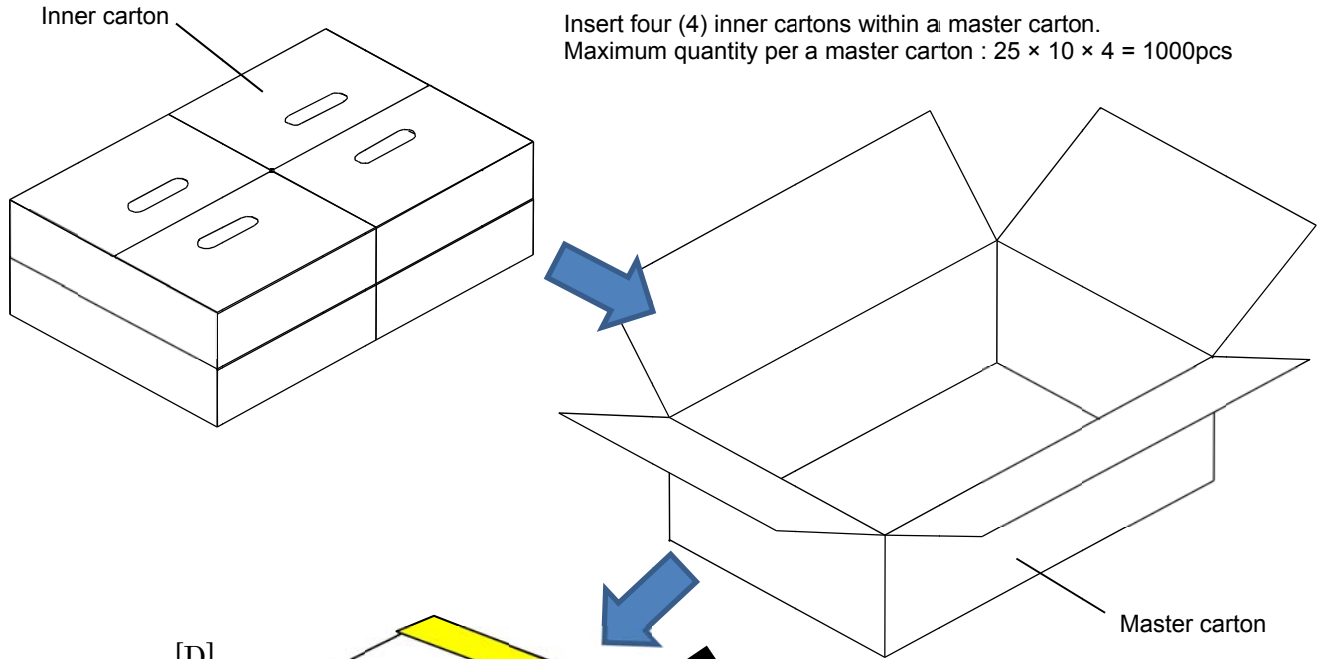

Insert four (4) inner cartons within a master carton.  
 Maximum quantity per a master carton :  $25 \times 10 \times 4 = 1000\text{pcs}$

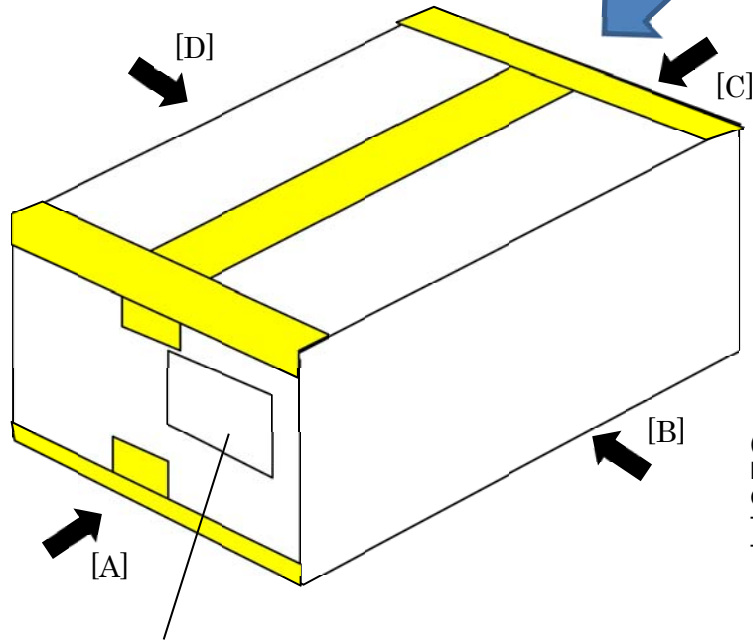

« Outer label »

(Notes)  
 Master carton size : W397 × L598 × H227 (mm).  
 Gap is filled if necessary.  
 Tape is applied if necessary.  
 Tied if necessary.

Indication onto [A] [B] [C] [D] on master carton are shown as below



Outer label

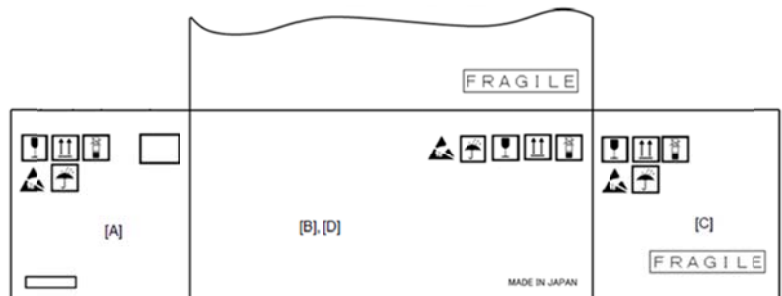



## 14. LCD MODULE USAGE AND PRECAUTIONS

### 14.1 HANDLING

- (1) The display panel is made of glass. Do not subject it to mechanical shock such as dropping it from a high position, etc.
- (2) If the display panel is damaged and internal liquid crystal substance leaks out, be sure not to inhale or consume it. If the internal liquid crystal substance comes into contact with skin or clothing, promptly wash it off using soap and running water.
- (3) Do not apply excessive force on the surface, perimeter or adjoining areas of LCD module since this may cause display panel color tone to vary.
- (4) The polarizer covering the display panel surface of the LCD module is soft and can be easily scratched. Handle this polarizer carefully.
- (5) If the surface polarizer becomes contaminated, use the following recommended or equivalent adhesive tape for contaminants removal.
  - Scotch-brand mending tape (No. 810)
- (6) Do not breathe on the display surface or use Ethyl Alcohol solvent for contaminant removal as polarizer discoloration may occur. Furthermore, solvent other than mentioned above may also damage the polarizer. Especially, do not use the followings.
  - Water
  - Ketones
  - Aromatic solvents
- (7) When mounting the LCD Module, be sure that it is free from twisting, warping, or distortion. Any stress can have great influence to the display quality. Also, in cases where outer case or frame is included, be sure to secure sufficient stiffness on the outer case or frame for a robust design.
- (8) Do not apply pressure at or around the FPC bonding area and the surrounding area.
- (9) Do not attempt to disassemble or rework the LCD module.
- (10) To prevent destruction of the elements by static electricity, be careful to maintain an optimum working environment.
  - Be sure to ground your body before handling the LCD module.
  - Make sure that solder guns and all other tools required for assembly have been grounded.
  - To reduce occurrence of static electricity, avoid using this product in dry environments.
  - A protective film has been attached to the surface of the LCD panel. When peeling off the protective film, be careful to prevent electrostatic discharges.
- (11) To minimize performance degradation of the LCD module caused by destructive forces such as static electricity, etc., avoid direct contact to the following sections when handling the LCD module.
  - terminal electrodes of connector
  - wiring pattern on FPC
- (12) LCD Panel surface is protected by a protective film layer. This protective film must be removed before final product installation. After removal of protective film layer, some adhesive residues maybe left on the LCD panel, especially after long storage period, please refer to section 5) listed above for proper contaminant removal procedure.
- (13) Take precaution to minimize corrosion of electrodes. Corrosion of electrodes is accelerated by moisture, condensation or a current flow in a high-humidity environment.
- (14) Do not apply excessive pressure to the FPC part. Force type such as twist, warp, etc., may damage FPC patterning traces.
- (15) Do not use sharp, pointy or rigid tools when handing LCD panels. These objects can scratch or nick the glass panel which can cause it to crack.
- (16) Do not touch or handle the LCD module directly with bare hands. Residue of dirt, oil or water may have the possibility to cause corrosion. Be sure to wear finger sacks or gloves when handling LCD modules. When holding an LCD panel module, carefully hold the panel by the edges of the glass plate.
- (17) Avoid using LCD module under condensation or high humidity environment because polarizer etc. maybe damaged in these conditions.
- (18) Trays are used to package LCD modules for shipment. If LCD modules scratch the tray during shipment, material of the scratched tray may be left on LCD modules. In such case, clean up LCD modules after removal from trays.
- (19) When installing LCD module, don't apply excess stress of bending or stretching to the input cable
- (20) Keep NC terminal open electrically.

- (21) After storage under high humidity or condensation environment, keep LCD module under room temperature more than 30 minutes before operation.
- (22) Take precautions to handling LCD module because the glass plate has very keen edges.

## 14.2 DESIGN OF APPLICATION

- (1) The absolute maximum ratings represent the rated values which LCD module cannot exceed. When LCD modules are used beyond this rated value, the operating characteristics may be adversely affected.
- (2) To prevent the occurrence of erroneous operation caused by noise, special attention on satisfying VIL, VIH specified values is required. This includes taking the precautionary measures of using short cables for signal transferring.
- (3) An inherent characteristic of liquid crystal display is its temperature dependency. Be sure to use the LCD modules within the specified operating temperature range, as recognition of the display becomes difficult when the LCD module is used outside its range. Also, keep in mind that the voltage levels necessary for clear display images will vary according to temperature.
- (4) It is recommended that power supply lines to include current surge protection. (Fuse etc. recommend value: 0.5A)
- (5) Note the peripheral devices can cause mutual noise interference with LCD modules. Especially, input devices such as Touch Panel, etc., may output operational level by radiation noise even when these devices are not in operation. Actual performance confirmation and verification under actual usage environment by actual final product is highly recommended.
- (6) To avoid EMI, preventive measures should be implemented in the final product.
- (7) Display abnormality may occur with sudden removal of power supply such as device battery. Sudden removal of power supply shall be avoided at all time. LCD module quality cannot be guaranteed under such condition.
- (8) Ensure sufficient light shading measures during design phase and when assemble the LCD module.
- (9) Ensure sufficient light shading measures in the inspection process.
- (10) Similar to general electronic components, ESD may cause LCD IC to malfunction. ESD preventive measures should be considered around the LCD module.
- (11) While display data may be kept, data can be easily changed by external noise. Noise shall be minimized at device or system level.
- (12) As unexpected noise may occur, periodic refresh operation such as resend the command and display data is highly recommended as part of the software routine.
- (13) When logic circuit power is off, do not apply any signals to the input terminals.
- (14) Do not use other components such as FPC or other features to fix the LCD module position, as pressure/tension may produce undesired result such as FPC trace crack.

## 14.3 DISPLAY CHARACTERISTICS

- (1) Because the optimum LCD driving voltage depends on the ambient temperature, display may slightly flicker at the environment of high temperature.
- (2) One of the special characteristics of liquid crystal is that it freezes when stored at the temperature below the storage temperature range. Such freezing may cause orientation defects or bubbles (black or white) to appear in the LCD panel. Bubbles may also occur if the panel receives an impact in a low-temperature environment.
- (3) If the LCD module is left operating for a long time with the same display showing, the displayed pattern may leave traces on the screen or the contrast may become inconsistent.

## 14.4 KEEPING THE PRODUCTS

- (1) When keeping LCD modules, avoid the following condition or environment.
- Exposure to direct sunlight or fluorescent lamps lightings.
  - High-temperature/high-humidity or very low-temperature (below 0°C) environments.
  - Exposure to water droplets, condensation, etc.

Furthermore, keep LCD modules in anti-static bags to prevent static electricity charge ups. Whenever possible, LCD modules should be stored in the same conditions in which they were shipped from Japan Display Inc.

- (2) Take precaution to minimize corrosion of electrodes. Corrosion of electrodes is accelerated by moisture, condensation or a current flow in a high-humidity environment.

(3) Recommended keeping conditions.

- Keeping environment : +15°C to 35°C, less than 65%RH
- Duration: up to 2 months after shipping date

(4) The shipping carton must not be stacked up over 1.5m in height.

#### 14.5 DISPOSAL

(1) When disposing LCD modules, consult company specialized in industrial waste treatment which is permitted by the government or local authority. When incineration is the method of LCD module disposal, law of environmental hygienic must be obeyed.

#### 14.6 OTHERS

(1) This product is designed to be used in ordinary electronic devices. Do not use this product in other applications, especially in devices that may cause direct bodily damage to end users (such as weapons, military purposes, aerospace equipment, life-support system equipment, or safety equipment).

(2) Japan Display Inc. shall not be responsible for defects that occur in this product or in equipment connected to this product if the product is used in an environment that exceeds the ranges specified in this document, or in an environment not described in this document.

15. OUTLINE DRAWING

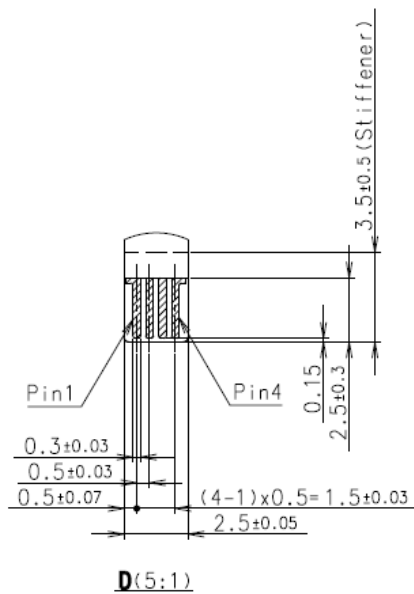
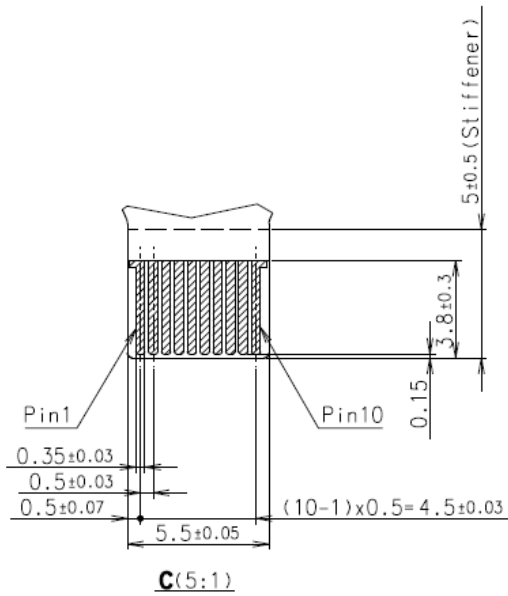
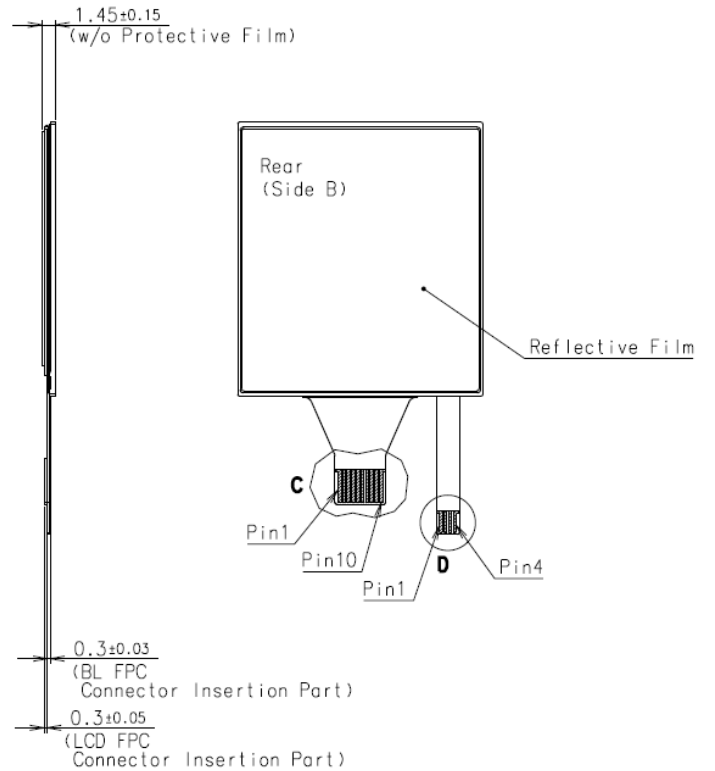
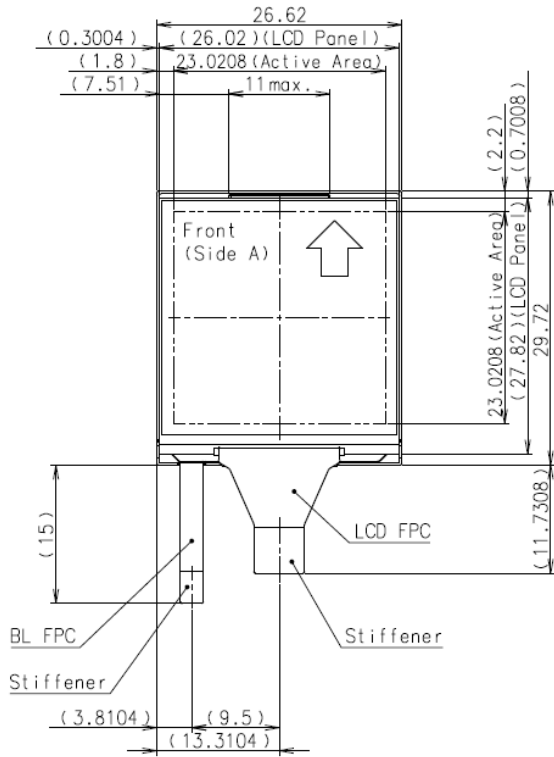

- Note
- 1) Unit : mm
  - 2) General tolerance: +/-0.2
  - 3) Scale: NTS
  - 4) Unless otherwise specified, radius shall be R0.5.
  - 5) Example of suitable FPC connector : LCD-FPC FH28-10S-0.5SH(05) 10pin / Hirose  
Backlight-FPC 503480-0400 / molex